

Why IPv6 in the home?

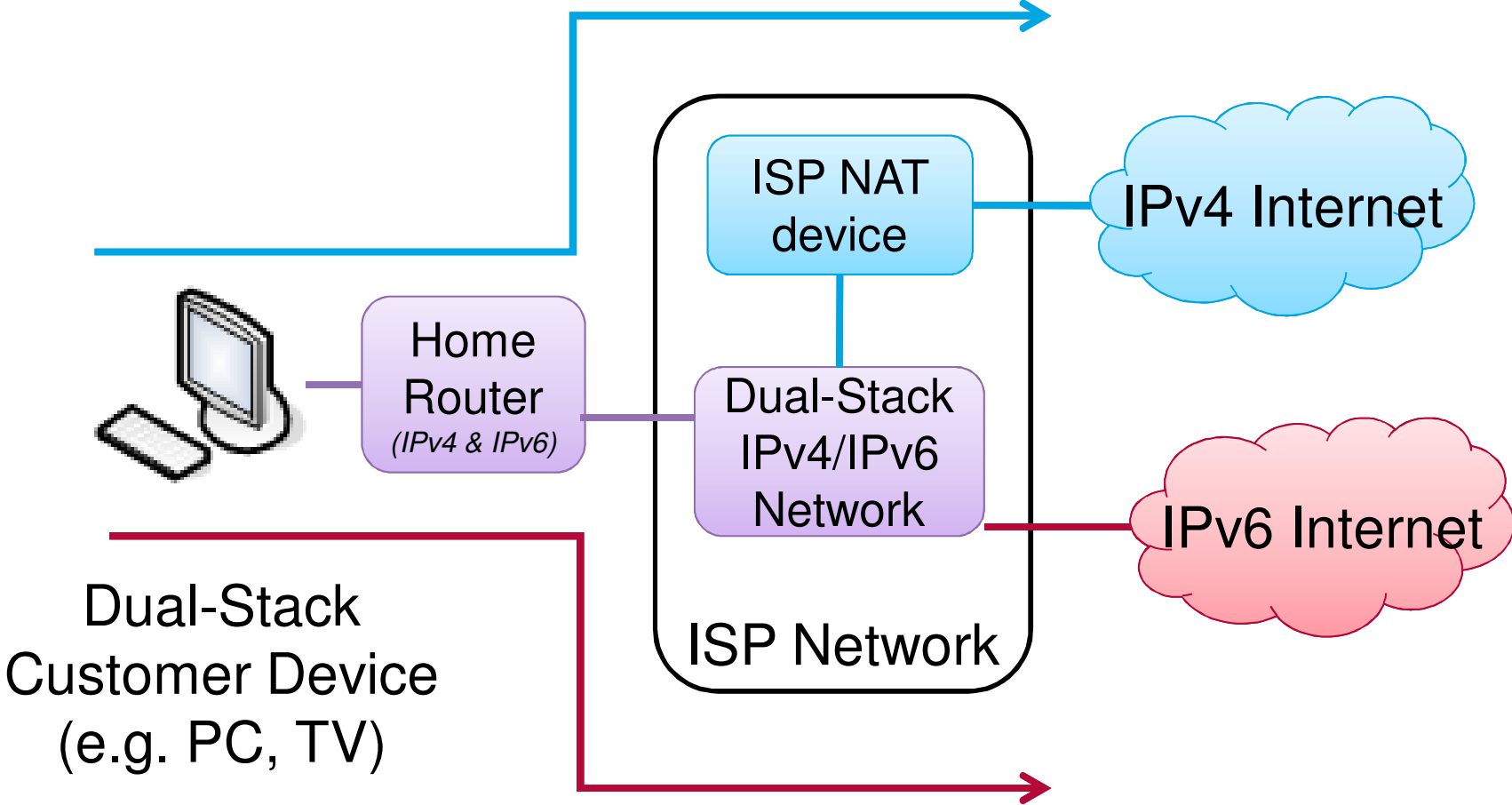

Dual-Stack
Customer Device
(e.g. PC, TV)

Dual-Stack (IPv4 & IPv6) PC and Home Gateway

IP network in the home

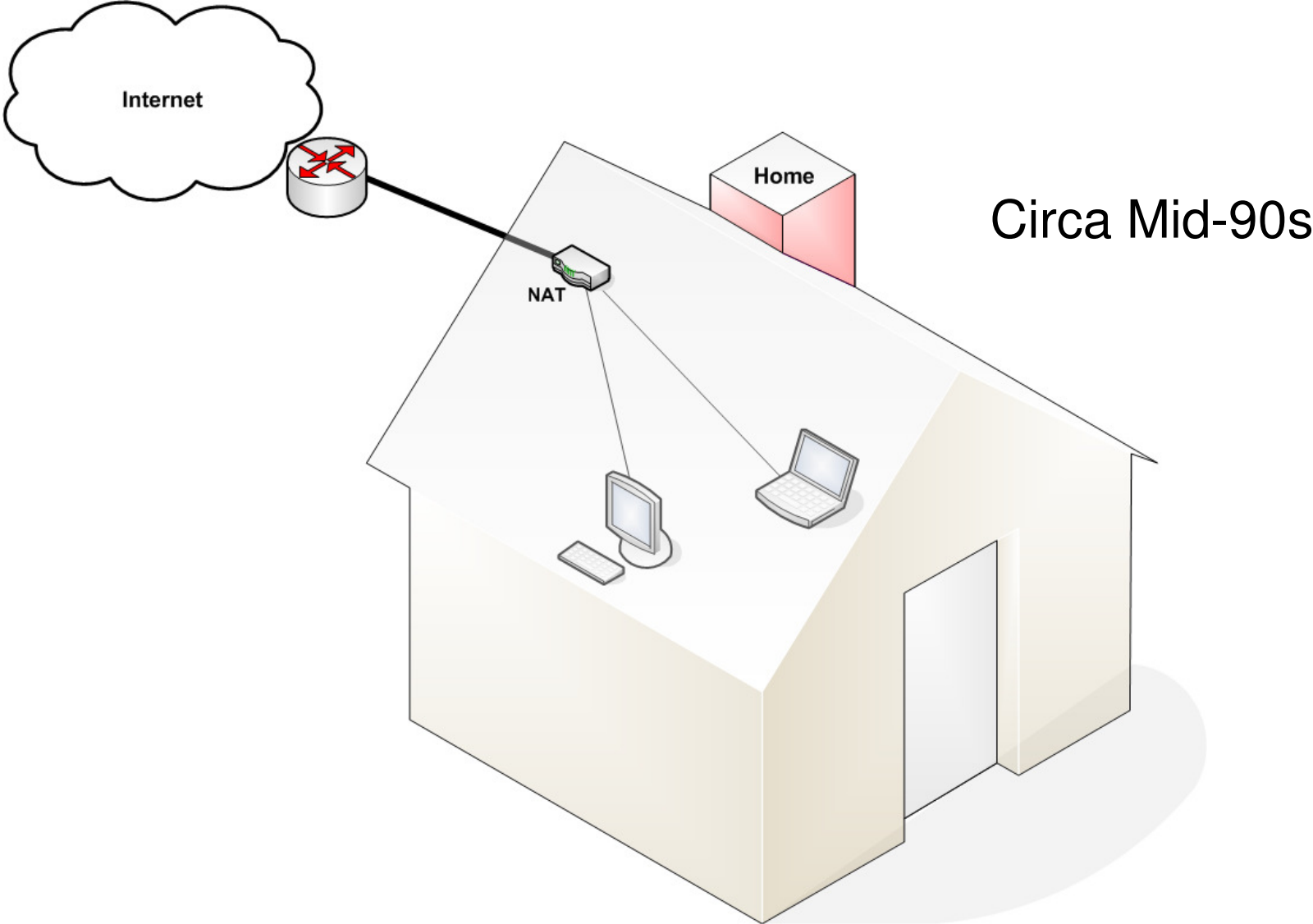

IP network in the home today

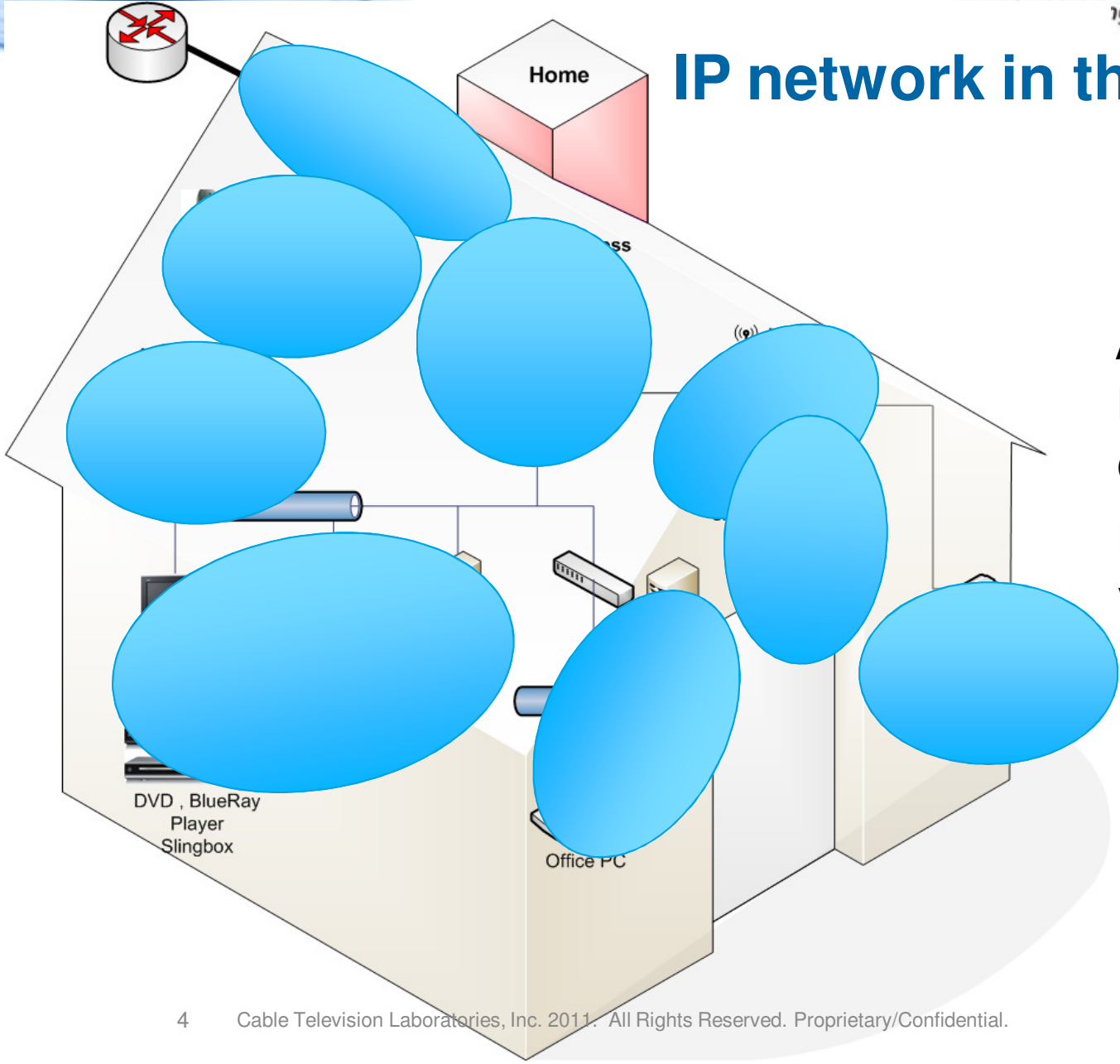

- Access Network
- Digital Phone Network
- Computer Network
- Entertainment Network
- Virtual Private Network
- Wireless Network
- Wireless Extension Network
- Personal Area Network
- Security Monitor Network

Topics to consider

- IPv6 Addressing
- IPv6 Device requirements
- Device/Service Discovery
- Home Transition plan for IPv6
- OS/Device readiness

IPv6 Addressing in the Home

- ISP provides an IPv6 prefix, DNS server via DHCP
- Default gateway through Router Advertisements
- No NAT, Subnets are assigned to router interfaces, and devices are assigned Globally Unique Addresses
- Unique Local Address
 - Prefix for use within home when Global is unavailable
 - Brokenness issue

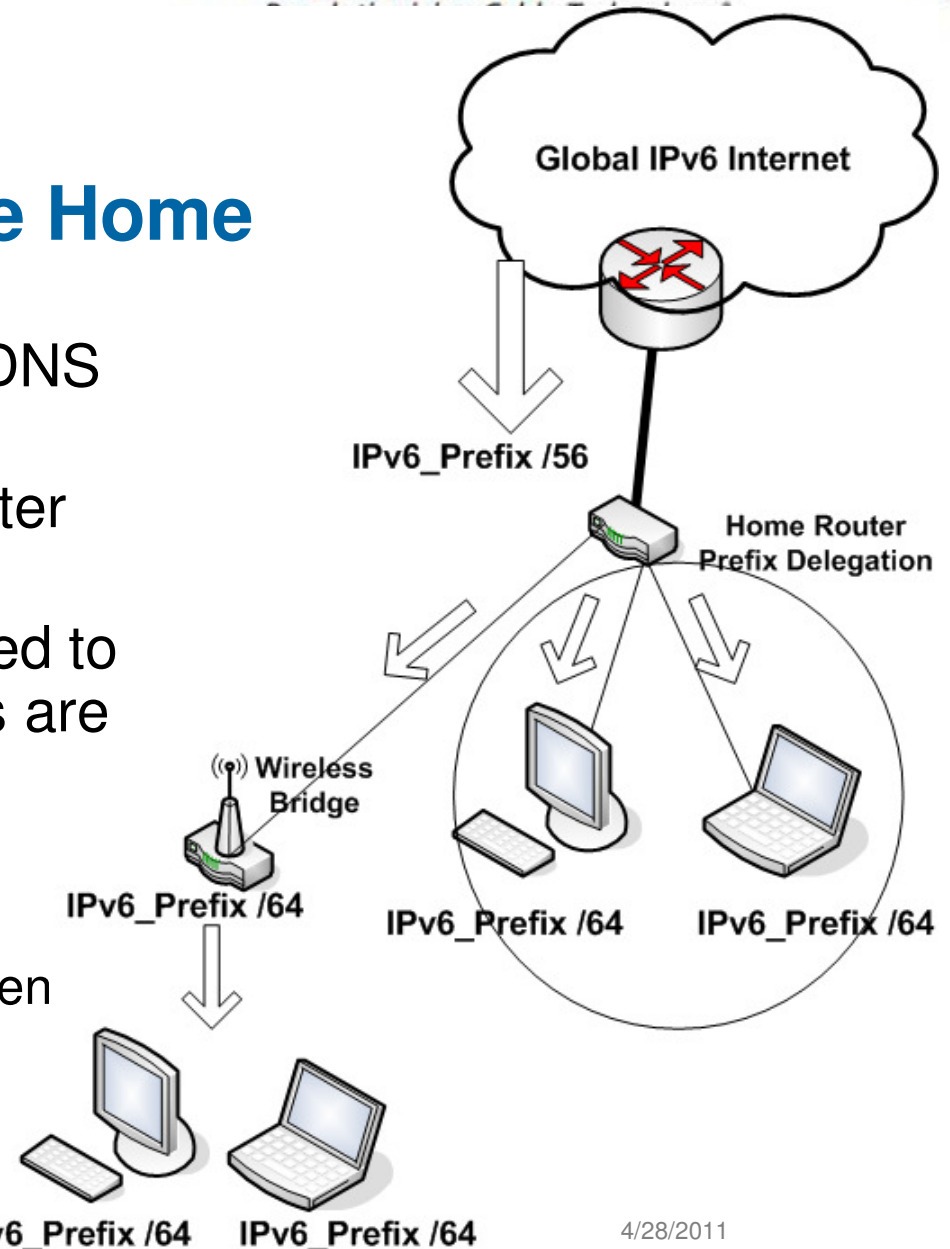

IPv6 Address Assignment

- SLAAC : Stateless Address Auto Configuration
 - Router announces prefix, gateway, maybe DNS
 - Hosts configure themselves based on Router Advertisements
 - Interface ID derived from MAC, Privacy extensions
 - Stateless DHCP: DHCP server can advertise DNS server information, NTP etc.
- Stateful DHCPv6
 - RAs for Default Gateway
 - Hosts send out DHCP Solicit, Router responds
 - Router gives out prefixes and or addresses, DNS information

IPv6 Host Requirements

- Basic Requirements
 - Stateless Address Autoconfiguration (RFC 4862)
 - Recursive DNS Server Option (RFC 6106)
 - Stateless DHCPv6 (RFC 3736)
- Advanced Requirements
 - Stateful DHCPv6 (RFC 3315)
- Home electronics
 - UPnP support for IPv6
 - DLNA support for IPv6 (when available)

IPv6 Home Router Requirements

- Basic Requirements (2011)
 - Defined in CableLabs eRouter [specification](#)
 - IETF RFC 6204 adds Broadband Forum requirements
 - Stateful firewall, Simple Security (RFC 6092)
- Advanced Requirements (2012)
 - Dual-Stack Lite ([draft-ietf-softwire-dual-stack-lite-07](#))
 - 6RD (RFC 5969)
 - IPv6 Multicast

DNS/Service Discovery in the home

- How do I find my local File Server?
- Multicast DNS (mDNS) : “serverless DNS”
 - DNS queries over IP Multicast in a small network where no conventional DNS server has been installed
 - Network prefix can change after a modem reset and change internal addresses, no need to update all those /etc/host entries
 - Useful for ad-hoc networks as well
 - mDNS doesn't cross router boundary
 - Zeroconf WG
- Service Discovery
 - DNS Service Discovery (mDNS/DNS-SD)
 - Universal Plug and Play (UPnP)

Multicast DNS (mDNS) in the home

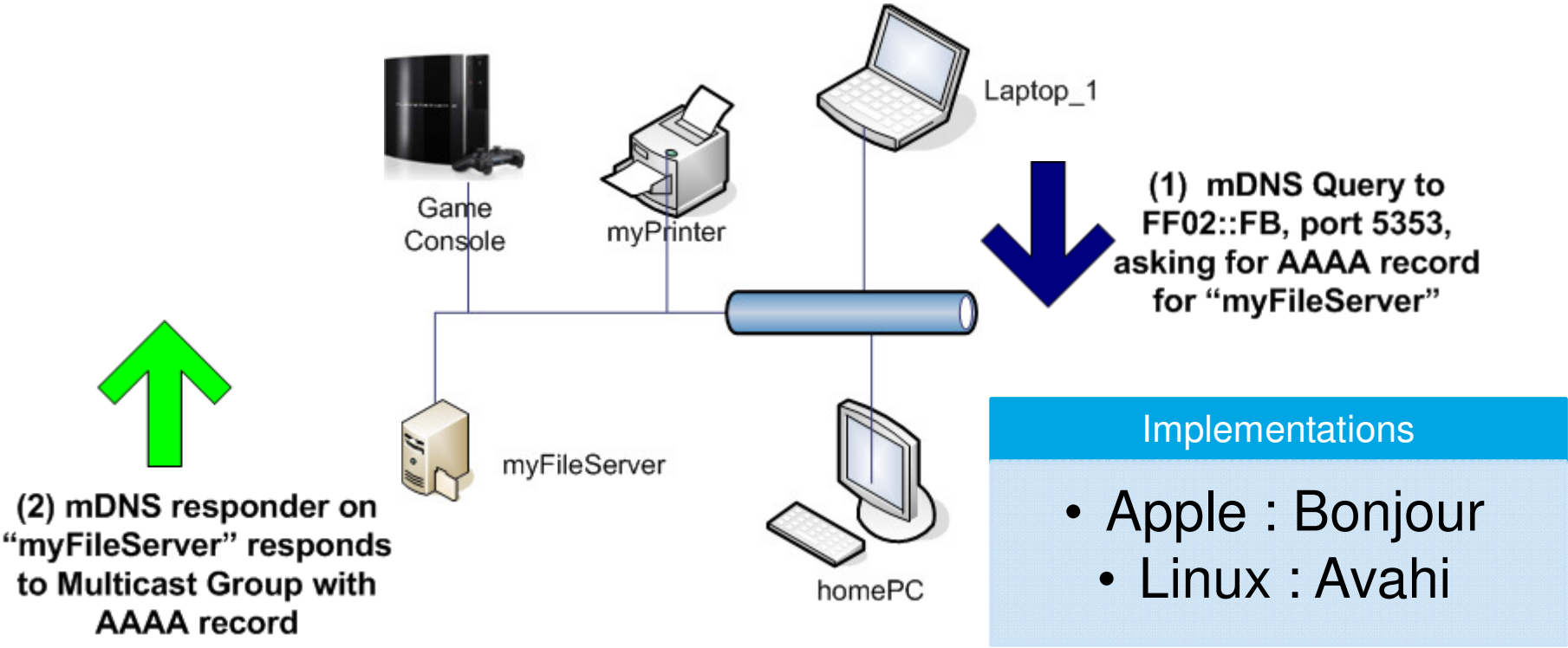

Preparation for Home transition to IPv6

- OS upgrade for computers with IPv6 support
- Mobile Devices/Tablets with IPv6 Support
- Home Router/Gateway with IPv6 support
 - Subnets and Addressing
- IPv6 enabled Internet connection : (e.g. D3.0 CM)

- Look for 'IPv6 Ready' CE Equipment
 - Internet Connected TVs : 'IPv6' Internet ready
 - Game Consoles (PS3, XBOX etc)
 - NAS devices etc
- IPv6 Security Wireless Cameras
- Advanced Devices (Smart Grid/SmartHome)

OS Readiness for IPv6

- Linux
 - Has long had IPv6 support
- Windows 7, Vista, Windows Server 2008 R2
 - Comes with IPv6 support
 - XP ** (need to install IPv6, hard)
- Apple Mac OS X
 - Automated IPv6 support, using KAME open-source IPv6 stack
 - No support for DHCPv6
- Android, Apple iOS, Symbian all support IPv6

Home Router Readiness for IPv6

- Consumer/SOHO equipment
 - Some products launched this year will support IPV6
 - D-Link, Netgear and Apple devices support IPv6
 - This list isn't exhaustive
 - IPv6 Ready Logo Program Approved List
- Add IPv6 support yourself : DD-WRT/Open-Wrt
 - You're tech-savvy
 - Your old router supported by DD-WRT or Opensource SW
 - Read DD-WRT IPv6 guide, make sure ISP supports IPv6

The path to IPv6 ...

- IPv6 – Coming soon to a home near you
- IPv4 & IPv6 will coexist for a long time
- IPv6 enables advanced home networking
 - Devices implementing basic IPv6 Infrastructure needs to be installed in the home
 - Enabling IPv6 not complicated, once you have the right components
- Basics are well-defined, but advanced technology is still work in progress

THANKS !

Karthik Sundaresan
k.sundaresan@cablelabs.com